

Body Control Module (BCM) C3

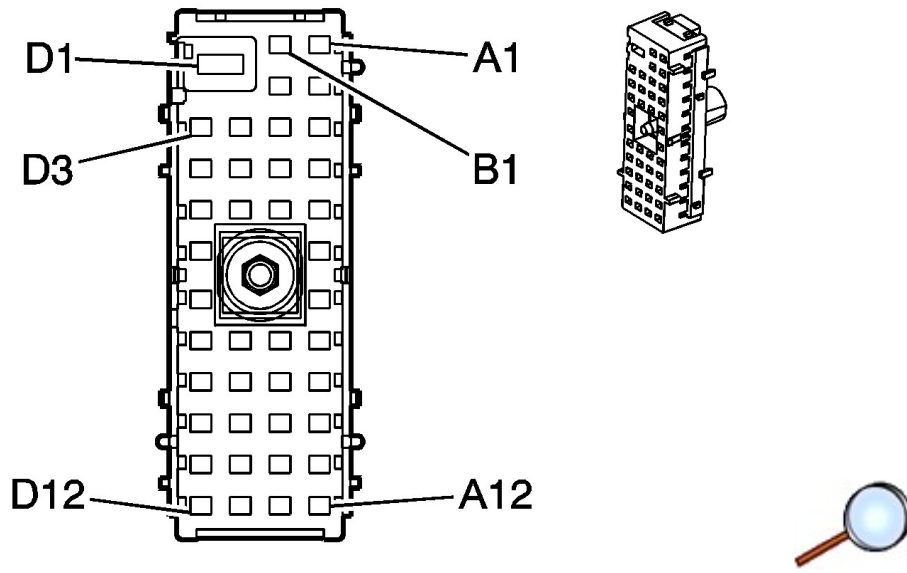

Connector Part Information

- OEM: 15492675
- Service: 88988613
- Description: 41-Way F Metri-Pack 280, 800 Series (RD)

Terminal Part Information

- Terminal/Tray: 12110844/4
- Core/Insulation Crimp: E/4
- Release Tool/Test Probe: 15315247/J-35616-4A (PU)

Body Control Module (BCM) C3

| Pin | Wire Color | Circuit No. | Function |
|-----|------------|-------------|---|
| A1 | TN | 294 | Door Lock Actuator Unlock Control (AU3) |
| A2 | TN | 294 | Door Lock Actuator Unlock Control (AU3) (Sedan) |
| | TN | 294 | Door Lock Actuator Unlock Control (AU3) (Sedan) |
| A3 | D-BU/WH | 149 | Courtesy Lamp Supply Voltage |
| A4 | GY | 295 | Door Lock Actuator Lock Control (AU3) (Driver) |
| | GY | 295 | Door Lock Actuator Lock Control (AU3) (Passenger) |

| Pin | Wire Color | Circuit No. | Function |
|--------|------------|-------------|---|
| A5 | GY | 295 | Door Lock Actuator Lock Control (AU3) (Sedan) |
| | GY | 295 | Door Lock Actuator Lock Control (AU3) (Sedan) |
| A6 | — | — | Not Used |
| A7 | BN | 9 | Park Lamp Supply Voltage |
| A8 | PK | 339 | Run/Crank Ignition 1 Voltage (UQ3) |
| A9 | YE | 18 | Left Rear Stop/Turn Lamp Supply Voltage |
| A10 | GY | 157 | Courtesy Lamp Control |
| A11 | — | — | Not Used |
| A12 | D-GN | 19 | Right Rear Stop/Turn Lamp Supply Voltage |
| B1 | TN | 694 | Driver Door Lock Actuator Unlock Control |
| B2 | — | — | Not Used |
| B3 | RD/WH | 1240 | Battery Positive Voltage |
| | RD/WH | 1240 | Battery Positive Voltage |
| B4 | — | — | Not Used |
| B5 | BN | 4 | Accessory Voltage |
| | BN | 4 | Accessory Voltage (L61/LE5) |
| B6-B7 | — | — | Not Available |
| B8-B11 | — | — | Not Used |
| B12 | GY | 8 | Instrument Panel Lamp Supply Voltage (LSJ) and (J41) |
| | GY | 8 | Instrument Panel Lamp Supply Voltage (L61/LE5) |
| B12 | GY | 8 | Instrument Panel Lamp Supply Voltage (L61/LE5) |

| Pin | Wire Color | Circuit No. | Function |
|------------|-------------------|--------------------|--|
| C1-C2 | — | — | Not Available |
| C3 | D-GN | 1301 | Retained Accessory Power Fuse Supply Voltage |
| C4 | — | — | Not Used |
| C5 | D-GN | 801 | Retained Accessory Power Fuse Supply Voltage |
| C6-C7 | — | — | Not Available |
| C8-C11 | — | — | Not Used |
| C12 | OG | 228 | Windshield Washer Pump Control |
| D1 | RD/BK | 142 | Battery Positive Voltage |
| D2 | — | — | Not Available |
| D3 | — | — | Not Used |
| D4 | RD/WH | 840 | Battery Positive Voltage |
| D5 | D-GN | 801 | Retained Accessory Power Fuse Supply Voltage |
| D6 | PK | 739 | Run/Crank Ignition 1 Voltage |
| D7 | PK | 1339 | Ignition 1 Voltage |
| D8-D9 | — | — | Not Used |
| D10 | RD/BK | 442 | Battery Positive Voltage |
| D11 | — | — | Not Used |
| D12 | RD/WH | 242 | Battery Positive Voltage |

Body Control Module (BCM) C4

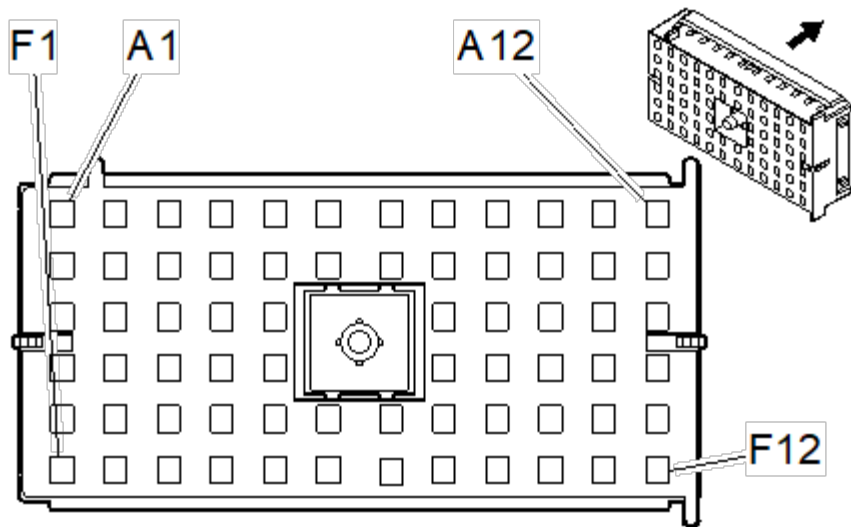

Connector Part Information

- OEM: 15492668
- Service: 88988776
- Description: 68-Way F Metri-Pack 280 Series (L-GY)

Terminal Part Information

- Terminal/Tray: 12110844/4
- Core/Insulation Crimp: E/4
- Release Tool/Test Probe: 15315247/J-35616-4A (PU)

Body Control Module (BCM) C4

| Pin | Wire Color | Circuit No. | Function |
|--------|------------|-------------|--------------------------------------|
| A1 | RD/WH | 640 | Battery Positive Voltage (UQ3) |
| A2-A12 | — | — | Not Used |
| B1 | OG | 228 | Windshield Washer Pump Control |
| B2 | GY | 8 | Instrument Panel Lamp Supply Voltage |
| B3-B12 | — | — | Not Used |
| C1 | RD/WH | 1440 | Battery Positive Voltage |
| C2 | GY | 8 | Instrument Panel Lamp Supply Voltage |

| Pin | Wire Color | Circuit No. | Function |
|------------|-------------------|--------------------|--------------------------------------|
| | GY | 8 | Instrument Panel Lamp Supply Voltage |
| C3-C5 | — | — | Not Used |
| C6-C7 | — | — | Not Available |
| C8 | BN | 4 | Accessory Voltage |
| C9-C10 | — | — | Not Used |
| C11 | GY | 8 | Instrument Panel Lamp Supply Voltage |
| C12 | GY | 8 | Instrument Panel Lamp Supply Voltage |
| D1 | RD/WH | 1040 | Battery Positive Voltage |
| D2 | — | — | Not Used |
| D3 | YE | 5199 | Run/Crank Voltage |
| D4 | BN | 141 | Ignition 3 Voltage |
| D5 | — | — | Not Used |
| D6-D7 | — | — | Not Available |
| D8-D9 | — | — | Not Used |
| D10 | RD/WH | 1140 | Battery Positive Voltage |
| | RD/WH | 1140 | Battery Positive Voltage |
| D11-D12 | — | — | Not Used |
| E1 | RD/WH | 140 | Battery Positive Voltage |
| E2-E5 | — | — | Not Used |
| E6 | PK | 439 | Ignition 1 Voltage |
| | PK | 439 | Ignition 1 Voltage (Coupe) (TV5) |
| E7-E11 | — | — | Not Used |
| E12 | BK/WH | 651 | Ground |
| F1 | RD/WH | 1540 | Battery Positive Voltage |

| Pin | Wire Color | Circuit No. | Function |
|------------|-------------------|--------------------|--------------------------------------|
| | RD/WH | 1540 | Battery Positive Voltage |
| F2 | — | — | Not Used |
| F3 | GY | 8 | Instrument Panel Lamp Supply Voltage |
| | GY | 8 | Instrument Panel Lamp Supply Voltage |
| F4 | PK | 339 | Ignition 1 Voltage |
| | PK | 339 | Ignition 1 Voltage |
| F5 | PK | 339 | Ignition 1 Voltage |
| | PK | 339 | Ignition 1 Voltage |
| F6 | PK | 339 | Ignition 1 Voltage |
| F7-F8 | — | — | Not Used |
| F9 | PK | 1539 | Ignition 1 Voltage |
| | PK | 1539 | Ignition 1 Voltage |
| F10-F12 | — | — | Not Used |